

FREQUENCY CENTRAL

Build documentation for:
KLANG STADT
DIGITAL WAVETABLE OSCILLATOR
a.k.a. Waverider Mk4

Klang Stadt is the latest FC iteration of Tom Wiltshire's VCDO digital wavetable oscillator. It features a number of advantages over our previous Waverider design:

- improved PWM filtering
- addition of Sub Two output
- addition of Klang output
- addition of Xmod feature
- onboard LFO for riding the waves

If the Klang output worries you, you can cover it over with a bit of masking tape. That's what I've done with mine.

Klang Stadt is based around the most excellent Electric Druid's PIC 16F1847 **VCDO1**:
<http://www.electricdruid.net/datasheets/VCDO1Datasheet.pdf>

Main PCB

Pots 'n' sockets PCB

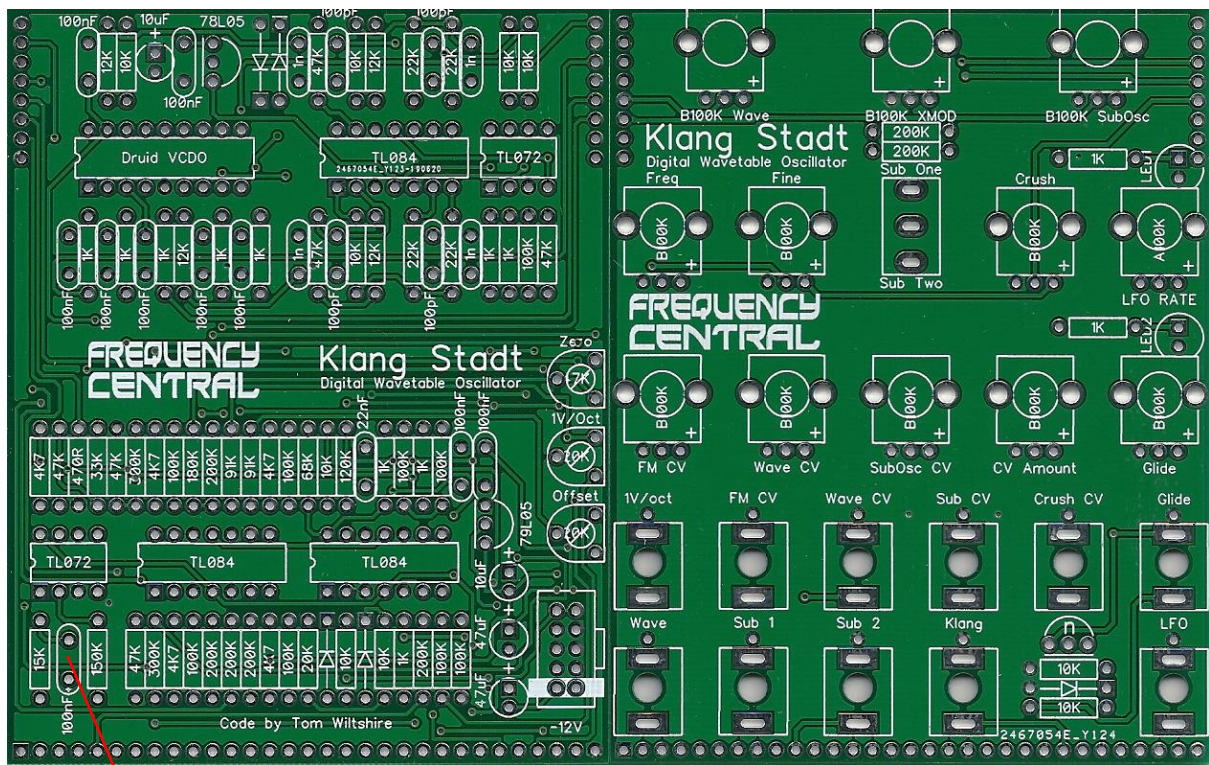

LFO timing capacitor*

Klang Stadt features a 2 PCB set:

- Main PCB
- Pots 'n' sockets PCB

Key to PCB screen print:

n: This signifies NPN BC547 transistors. Note the correct pinout as shown by the half circles. The PCB shows the correct orientation for BC547. Other transistor types can be used (eg 2N3904), but please observe the correct pinout.

Please observe correct polarity of the electrolytic caps, voltage regulators, transistor, ICs etc!

Bill of Materials

470R x 1	100pF x 4	VCDO1 PIC x 1**	B100K x 3
1K x 12	1nF x 4		
4K7 x 5	100nF x 9	TL084 x 3	A100K x 1
10K x 11	10uF x 2	TL072 x 2	(or this)***
12K x 4	47uF x 2		
15K x 1		BC547 x 1	B100K x 8
20K x 1	470nF or 1uF x 1*	78L05 x 1	(or these)***
22K x 4		79L05 x 1	
33K x 1			SPDT toggle x 1
47K x 5		1N4148 x 5	
68K x 1		3mm red LED x 2	20K trimmer x 2
91K x 2			47K trimmer x 1
100K x 9			All trimmers are 6mm (Tayda)
120K x 1			
150K x 1			3.5mm socket x 11
180K x 1			
200K x 7			Male 40 pin header x 2
300K x 2			Female 40 pin header x 2
All resistors ¼ watt metal film.			10 pin box header
Theres one extra remember!!			Big knob x 2
69			Little knob x 1

* I have come to the conclusion that the LFO range is a matter of taste. For my applications, I'm finding 470nF suits best. 100nF (as on the screenprint) is a bit fast for lazy wavetable morphings. If you wanna go really slow, use 1uF here instead. Hey, maybe even socket and flip between a few values, then decide.

** You can buy this from me, or from Electric Druid, or some other place.

*** I prefer the Song Heui tall trimmers because they have a longer shaft and a white notch.

Main PCB:

Populate the Main PCB as shown on the silkscreen, starting with the lowest profile components, so:

- Resistors, diodes
- IC sockets
- Non-electrolytic capacitors, transistors, trimmers
- Power header
- Electrolytic capacitors

Finally, cut 3 male header strips to the correct lengths (8, 8, 31) and solder to the PCB so that the long legs stick out of the rear of the PCB.

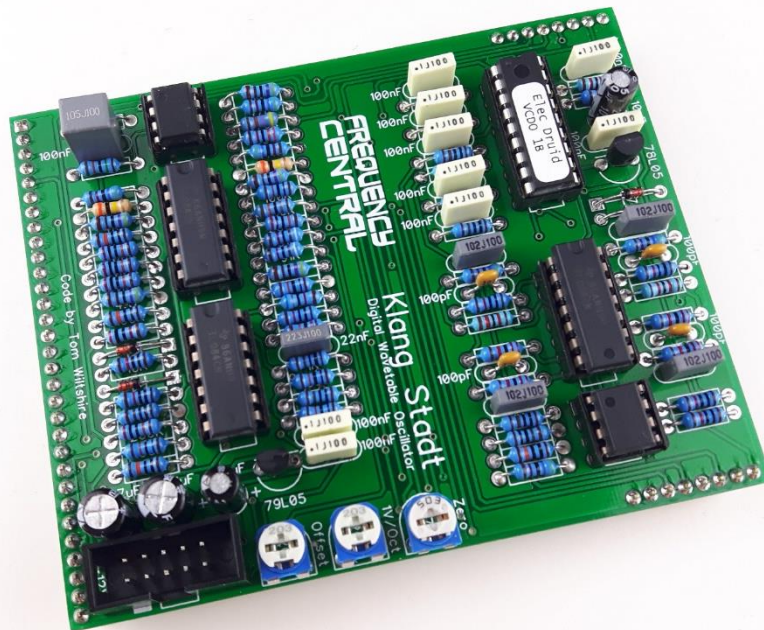

Pots 'n' sockets PCB

Populate the Panel PCB as shown on the silkscreen in this order:

- Resistors (see photos below for minor change before continuing) and diode
- Transistor
- **Don't do the LEDs yet!**
- The upper 3 potentiometers, the switch and the sockets. Use the panel to make everything line up nicely.
- The other 9 potentiometers
- Cut 3 female header strips to the correct lengths (8, 8, 31) and solder to the PCB so that the black parts stick out of the rear of the PCB.
- Pop the LED through its pads on the PCB – **don't solder it yet!** Put the panel back together with the panel PCB, push the LED through the panel, making sure that it sits right, now solder it in place.

Oops, we made an error! We can't justify trashing this batch of PCBs for this small error, so here's the fix. If your PCB shows a 10K resistor in this spot then there is no need to do the fix.

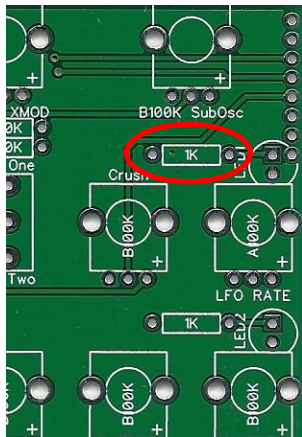

Do not fit this 1K resistor!



Instead do this with a 10K resistor.

Plug the Main PCB into the Panel PCB...you're done!

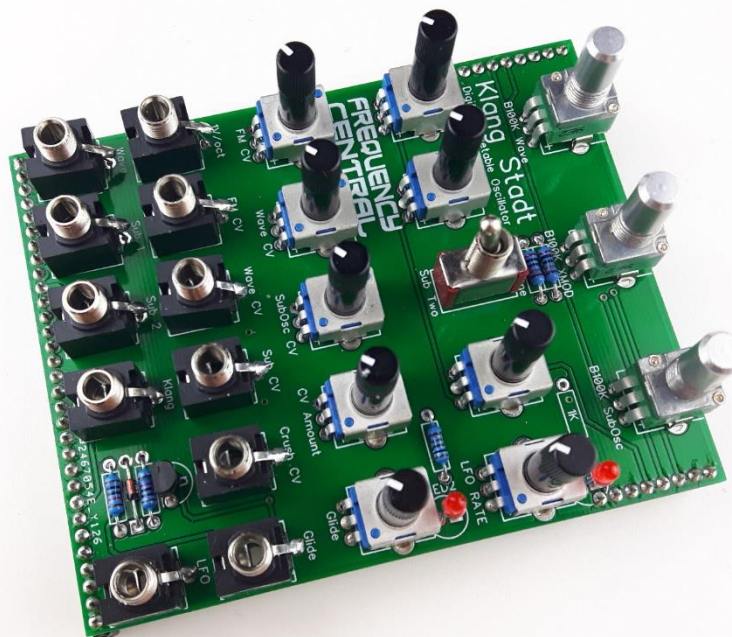

Tracking/calibration procedure

- Send a 1V/oct source into Frequency CV input
- On plug-in with all trimmers in the mid position you should find that the bottom notes of a 5 octave keyboard don't do anything. So, trill between bottom C and C#, and adjust the Offset trimmer until both notes sound. You've just set up the CV offset.
- Play a couple of C's an octave apart towards the middle of the keyboard, adjust the 1V/oct trimmer until they are true. Then play every note on the keyboard, listen for any trilling notes - that means the note isn't quite sure what it wants to be. Fine tune Offset trimmer and 1V/oct trimmer until everything is cool, playing octaves and finally every damned note!

- Set Detune knob to 12 o'clock, match Waverider to a known pitch source using Zero trimmer. If you have an O'Tool = even easier: play an A on the keyboard, find a note close to A4 on the Frequency pot, adjust Zero trimmer to 440Hz.
- Takes about 5 minutes...!

RDH 13/08/19

<http://www.frequencycentral.co.uk/>

